

Doc. No. : MD4-PS-060

Rev. : 0

Date : 26.02.90

MAESTRO D MODULE - 4MHz GENERAL PRODUCT SPECIFICATIONS

- A. Current Consumption : a) Normal mode at V.Ad (SW6) = 9V
Measured at V+ of PIO connector
130mA typical
200mA max.
b) Memory mode at V.Ad = 9.0V
Measured at V+ of PIO connector
0.5uA typical
10uA max.
- B. Power Consumption : 1.17W typical
1.8W max.
- C. System Clock Frequency : 4MHz +/- 1%

PREPARE BY : 

APPROVED BY : 

MAESTRO D MODULE - 4MHz
TROUBLE-SHOOTING CHART

7

SYMPTOMS	POSSIBLE CAUSES
<p>Unit will not turn-on</p>	<ol style="list-style-type: none"> 1) Check Vcc for 4.75 - 5.25V If Vcc is not within this range : <ol style="list-style-type: none"> i) Check U24 pin 1 input for higher than 7V, if not, defective adapter circuit. ii) Check V+ pin 15 of edge connector for higher than 7.5V, if not, defective adapter. iii) Check PW pin 12 of edge connector for higher than 4V, if not, check R3, R4. iv) Check for broken connection(s) between edge socket connector and logic PCB. 2) Check clock circuit - check clock frequency at U1 pin 39 for 4MHz +/- 1% square wave, if not. <ol style="list-style-type: none"> i) Check U18, U17, U10, U21, R33, C31. ii) Defective U1, crystal X1. 3) Check reset circuit - check U1 pin 40 for the changes of logic 'low' to logic 'high' state when power is switched from OFF to ON. if not. <ol style="list-style-type: none"> i) check C4 at power up. ii) check Q6, R10, R11, Z2. iii) defective U18, C4, R12, D2, C29. 4) Check for defective IC. 5) Check for broken traces. 6) Check for bad contacts between IC and IC socket.
<p>MODULE TESTER test</p> <ol style="list-style-type: none"> 1) LED 1 to 8 on tester not scanning <ol style="list-style-type: none"> a) LED 1 not light up b) LED 2 not light up c) LED 3 not light up d) LED 4 not light up e) LED 5 not light up f) LED 6 not light up g) LED 7 not light up h) LED 8 not light up 2) All 8 LEDs not light up 3) Only one of 8 LEDs lights up 4) NMI pin test LED lights up 5) RTS-P test LED not toggle 	<ul style="list-style-type: none"> - ROM failure : defective U2 or broken traces. - ROM failure : defective U3 or broken traces. - ROM failure : defective U4 or broken traces. - RAM failure : defective U5 or broken traces. - ROM failure : defective U2 or broken traces. - ROM failure : defective U3 or broken traces. - ROM failure : defective U4 or broken traces. - RAM failure : defective U6 or broken traces. <ul style="list-style-type: none"> - Check for broken connections between edge socket connector and logic PCB. - Check connections between U11 pin 10 and U16 pin 4. - Defective U9, U11, U13, U16. <ul style="list-style-type: none"> - Check connection to the corresponding lighted LED. - Defective U13, U14. <ul style="list-style-type: none"> - Edge socket pin 14 shorted to pin 15. <ul style="list-style-type: none"> - Check U1 pin 6 short to ground. - Check for broken connection between U9 pin 10 to the logic PCB. - Defective U9.

REVISION		
DATE	DESCRIPTION	ECN NO.
5/9/89	C2 CHANGE FROM 4.7UF TO 100UF	B900057

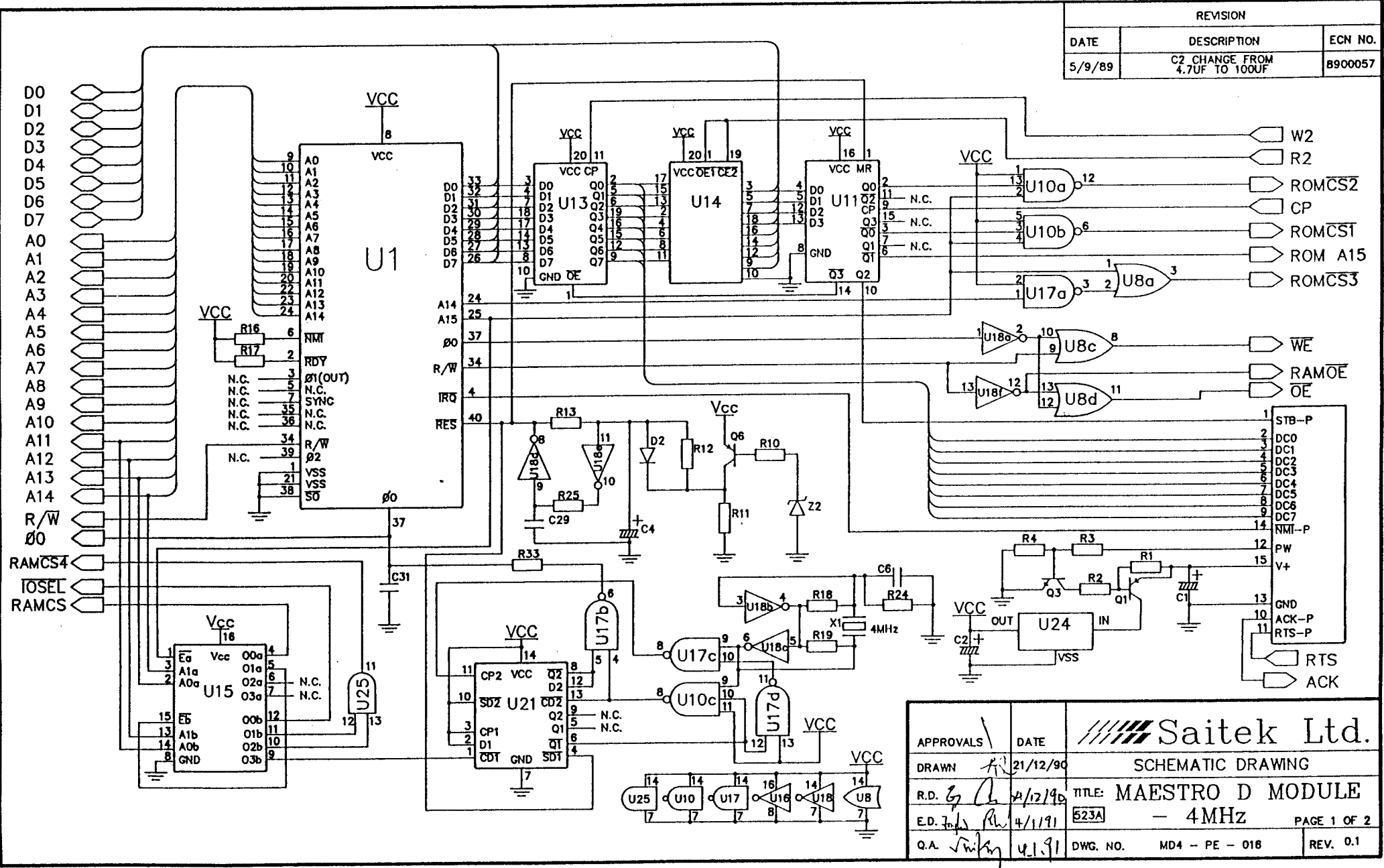

APPROVALS	DATE	 Saitek Ltd.
DRAWN	21/12/90	
R.D.	2/12/90	TITLE: MAESTRO D MODULE
E.D.	4/1/91	523A - 4MHz
G.A.	4.1.91	DWG. NO. MD4 - PE - 018
		PAGE 1 OF 2
		REV. 0.1

REVISION			
DATE	DESCRIPTION	ECN NO.	REV. NO.

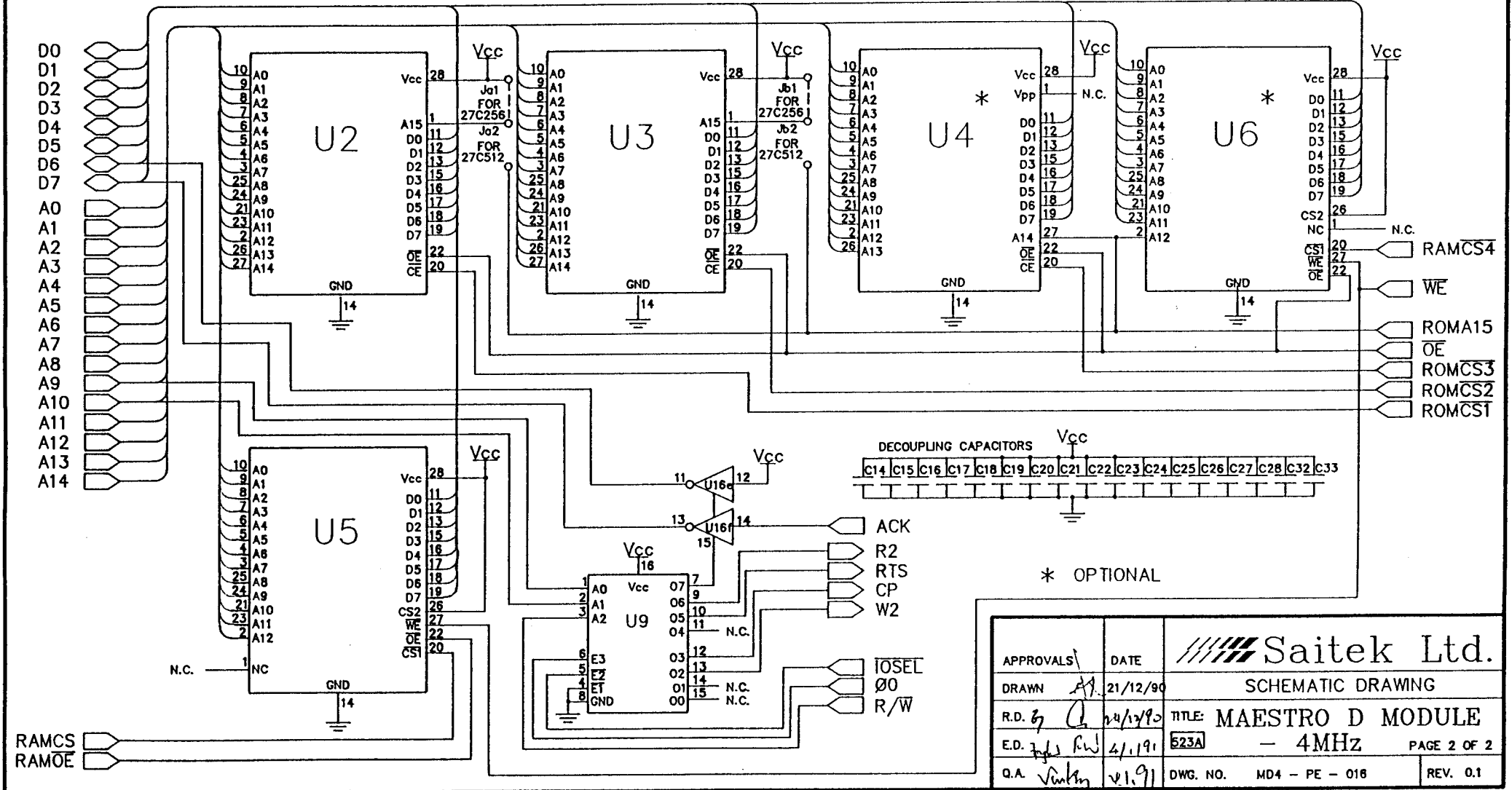

* OPTIONAL

APPROVALS	DATE	Saitek Ltd.	
DRAWN <i>AG</i>	21/12/90	SCHEMATIC DRAWING	
R.D. <i>Q</i>	24/12/90	TITLE: MAESTRO D MODULE	
E.D. <i>JWS RW</i>	4/1/91	523A	- 4MHz PAGE 2 OF 2
Q.A. <i>Vankay</i>	21/91	DWG. NO. MD4 - PE - 018	REV. 0.1