

Doc. No. : MD6L-PG-009

Rev. : 0

Date : 23.05.89

ANALYST D MODULE - 6MHz GENERAL PRODUCT SPECIFICATIONS

- A. Current Consumption
- a) Normal mode at V.Ad = 9V
130mA typical
200mA max.
 - b) Memory mode at V.Ad = 9.0V
Measured at V+ of PIO connector
0.5uA typical
10uA max.
- B. Power Consumption : 1.17W typical
1.8W max.
- C. System Clock Frequency : +/- 1% of the crystal frequency.

PREPARE BY :



APPROVED BY :

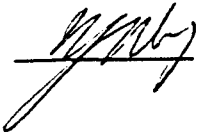

PROJECT : ANALYST D MODULE - 6MHz

Doc.No. : MD6L-PS-007

Rev. : 0

Date : 19.05.89

ADJUSTMENT PROCEDURE

OBJECT : To adjust system clock frequency

EQUIPMENT NEEDED : Frequency counter or Oscilloscope capable of frequency up to 10 MHz.

PROCEDURE : 1. Disassemble unit by removing screws(6) on bottom cover.
2. Power on unit
3. Place probe of counter/scope at pin 39 of U1. If frequency measured is out of specified range ($\pm 1\%$ of the crystal frequency), replace C6 until counter/scope reading is within specification.
4. Reassemble unit.

PREPARE BY :



APPROVED BY :

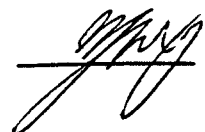

ANALYST D MODULE - 6MHz
TROUBLE-SHOOTING CHART

SYMPTOMS	POSSIBLE CAUSES
<p>Unit will not turn-on ("Module" LED of Leonardo-type chess computer does not light up when the module is inserted and the GO key is pressed).</p>	<ol style="list-style-type: none"> 1) A mains adapter is required to operate the modules. Ensure the chess computer is properly power by a Kasparov AC adapter with 7-9V output. 2) Check Vcc for 4.75-5.25V. If Vcc is not within this range : <ol style="list-style-type: none"> i) Check V+ pin 15 of edge connector for higher than 7.5V, if not, defective adapter. ii) Check U24 pin 1 input for higher than 7V, if not, defective adapter circuit. iii) Check PW pin 12 of edge connector for higher than 4V, if not, check R3, R4. iv) Check for broken connection(s) between edge socket connector and logic PCB. 3) Check clock circuit - check clock frequency at U1 pin 39 for 5.6MHz - 6MHz +/- 1% square wave, if not, <ol style="list-style-type: none"> i) check U18, U17, U10, U21, U22, U25, R33, C31. ii) Defective U1, crystal X1. 4) Check reset circuit - check U1 pin 40 for change of logic level from 'low' to 'high' state when power is switched from OFF to ON. if not, <ol style="list-style-type: none"> i) check C4 at power up. ii) check Q6, R10, R11, 22. iii) defective U18, C4, R12, D2, C29. 5) Check for broken traces. 6) Check for bad contacts between ICs and their IC socket. 7) Check for defective IC's.
<p>LCD module : no display</p>	<ol style="list-style-type: none"> 1) Check for broken traces. 2) Check for short traces. 3) Check for broken connection(s) between PCB and LCD. 4) Check VLC of LCD for range 0.16-0.2V. if not, check R21 and R20. 5) Check for pulse input at 'E' pin 6 of LCD. 6) Defective LCD. 7) Defective U1, U8, U16.
<p>MODULE TESTER test</p> <ol style="list-style-type: none"> 1) LED 1 to 8 on tester not scanning <ol style="list-style-type: none"> a) LED 1 not light up b) LED 2 not light up c) LED 3 not light up d) LED 4 not light up e) LED 5 not light up f) LED 6 not light up g) LED 7 not light up h) LED 8 not light up 2) All 8 LEDs not light up 3) Only one of 8 LEDs lights up 4) NMI pin test LED lights up 5) RTS-P test LED not toggle 	<ul style="list-style-type: none"> - ROM failure : defective U2 or broken traces. - ROM failure : defective U3 or broken traces. - ROM failure : defective U4 or broken traces. - RAM failure : defective U5 or broken traces. - ROM failure : defective U2 or broken traces. - ROM failure : defective U3 or broken traces. - ROM failure : defective U4 or broken traces. - RAM failure : defective U6 or broken traces. - Check for broken connections between edge socket connector and logic PCB. - Check connections between U11 pin 10 and U16 pin 14. - Defective U9, U11, U13, U16. - Check connection to the corresponding lighted LED. Defective U13, U14. - Edge socket pin 14 shorted to pin 15. - Check if U1 pin 4 short to ground. - Check for broken connection between U9 pin 10 to the logic PCB. - Defective U9.

Note : Plug in EGR EPROM Art. No. 518 in U4 before starting the Module tester test.

REVISION		
DATE	DESCRIPTION	ECN NO.
5/9/89	C2 CHANGE FROM 4.7UF TO 100UF	8900057

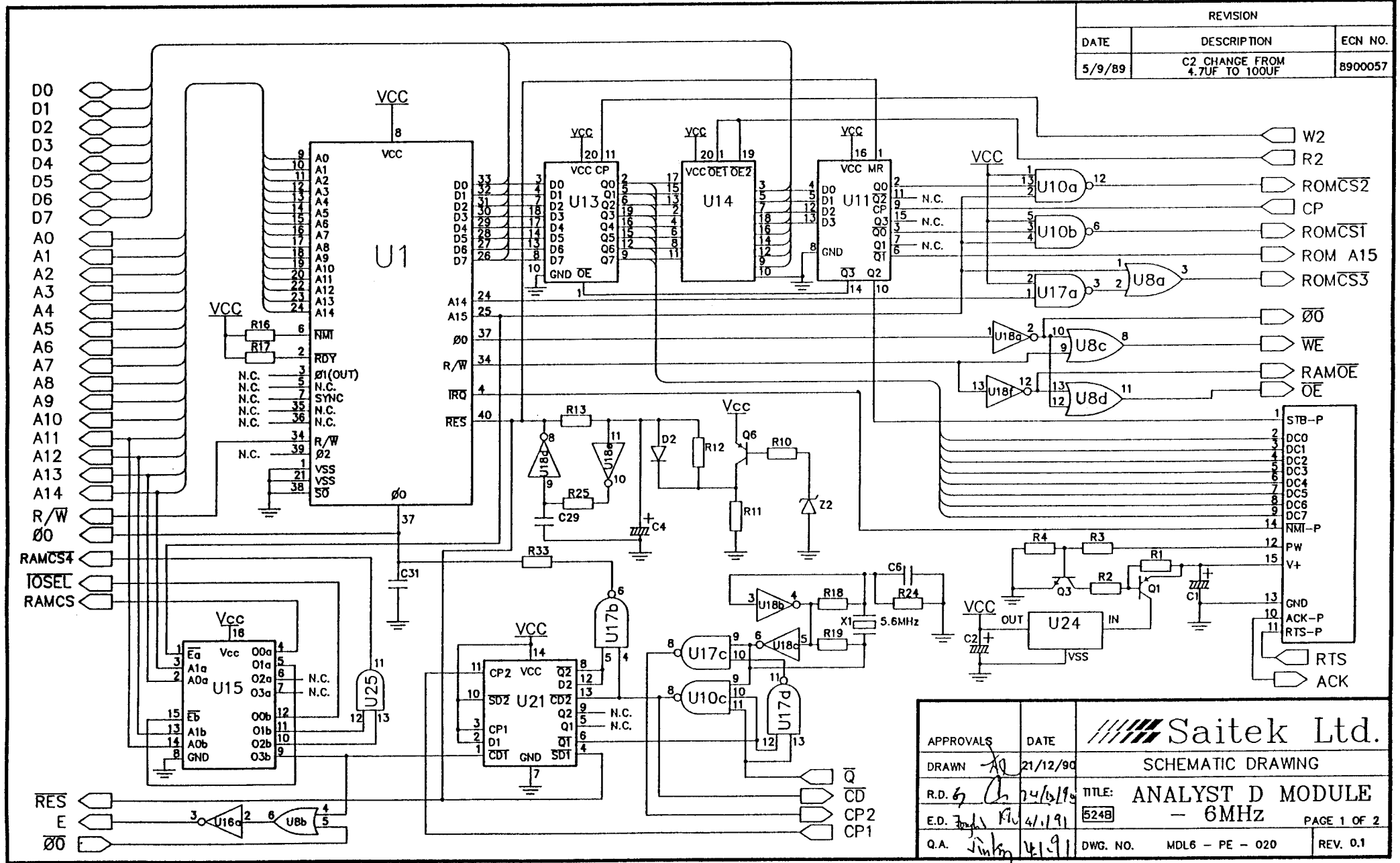

APPROVALS	DATE	 Saitek Ltd.	
DRAWN	21/12/90		SCHEMATIC DRAWING
R.D.	24/6/91		TITLE: ANALYST D MODULE
E.D.	4/1/91		524B - 6MHz
Q.A.	4/1/91		PAGE 1 OF 2
DWG. NO. MDL6 - PE - 020		REV. 0.1	

REVISION			
DATE	DESCRIPTION	ECN NO.	REV. NO.

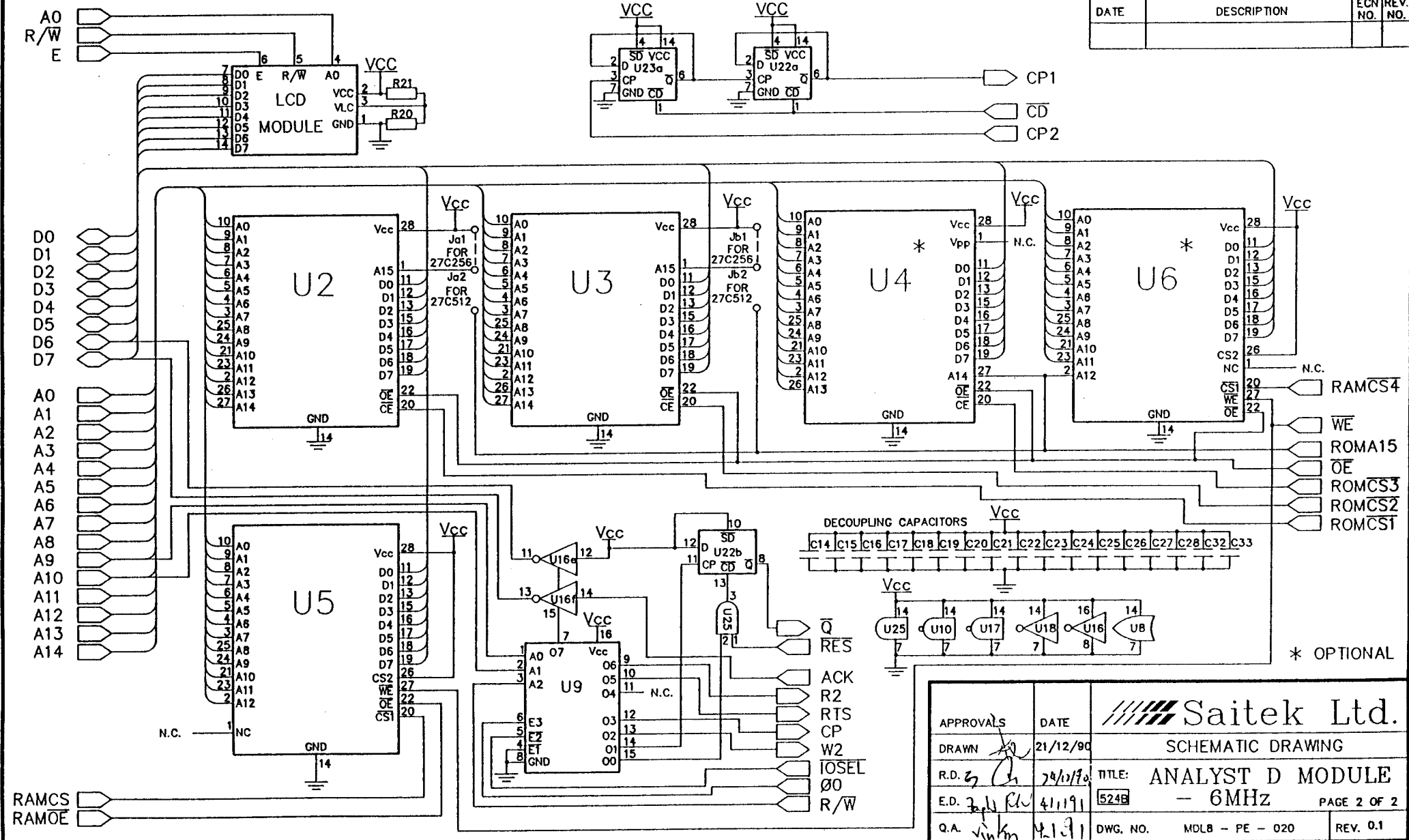

APPROVALS	DATE	
DRAWN <i>[Signature]</i>	21/12/90	
R.D. <i>[Signature]</i>	24/12/90	TITLE: ANALYST D MODULE
E.D. <i>[Signature]</i>	4/1/91	524B - 6MHz
Q.A. <i>[Signature]</i>	4/1/91	PAGE 2 OF 2
DWG. NO.	MDL8 - PE - 020	REV. 0.1